

Motorized Brush Cleaner

Installation, Operation and Maintenance Manual



Motorized Brush Cleaner

Serial Number:	_____
Purchase Date:	_____
Purchased From:	_____
Installation Date:	_____

Serial number information can be found on the Serial Number Label included in the Information Packet shipped in the cleaner carton.

This information will be helpful for any future inquiries or questions about belt cleaner replacement parts, specifications or troubleshooting.

Table of Contents

Section 1 - Important Information	2
1.1 General Introduction.....	2
1.2 User Benefits	2
1.3 Service Option.....	2
Section 2 - Safety Considerations and Precautions	3
2.1 Stationary Conveyors.....	3
2.2 Operating Conveyors.....	3
2.3 Other Hazards.....	3
Section 3 - Pre-Installation Checks and Options.....	4
3.1 Checklist.....	4
3.2 Optional Installation Accessories.....	4
Section 4 - Installation Instructions.....	5
Section 5 - Pre-Operation Checklist and Testing.....	10
5.1 Pre-Op Checklist.....	10
5.2 Test Run the Conveyor	10
Section 6 - Maintenance.....	11
6.1 New Installation Inspection.....	11
6.2 Routine Visual Inspection.....	11
6.3 Routine Physical Inspection	11
6.4 Drum Replacement Instructions.....	12
6.5 Maintenance Log.....	14
6.6 Cleaner Maintenance Checklist.....	15
Section 7 - Troubleshooting	16
Section 8 - Specs and CAD Drawings.....	17
8.1 Specs and Guidelines	17
8.2 CAD Drawing.....	18
Section 9 - Replacement Parts	19
9.1 Replacement Parts List	19
Section 10 - Other Flexco Conveyor Products.....	20

Section 1 - Important Information

1.1 General Introduction

We at Flexco are very pleased that you have selected a Motorized Brush Cleaner for your conveyor system.

This manual will help you to understand the operation of this product and assist you in making it work up to its maximum efficiency over its lifetime of service.

It is essential for safe and efficient operation that the information and guidelines presented be properly understood and implemented. This manual will provide safety precautions, installation instructions, maintenance procedures and troubleshooting tips.

If, however, you have any questions or problems that are not covered, please contact your field representative or our Customer Service Department:

Customer Service: USA: 1-800-541-8028

Visit www.flexco.com for other Flexco locations and products.

Please read this manual thoroughly and pass it on to any others who will be directly responsible for installation, operation and maintenance of this product. While we have tried to make the installation and service tasks as easy and simple as possible, **it does however require correct installation and regular inspections and adjustments to maintain top working condition.**

1.2 User Benefits

Correct installation and regular maintenance will provide the following benefits for your operation:

- Reduced conveyor downtime
- Reduced man-hour labor
- Lower maintenance budget costs
- Increased service life for the belt cleaner and other conveyor components

1.3 Service Option

The Motorized Brush Cleaner is designed to be easily installed and serviced by your on-site personnel. However, if you would prefer complete turn-key factory service, please contact your local Flexco Field Representative.

Section 2 - Safety Considerations and Precautions

Before installing and operating the Motorized Brush Cleaner, it is important to review and understand the following safety information.

There are set-up, maintenance and operational activities involving both **stationary** and **operating** conveyors. Each case has a safety protocol.

2.1 Stationary Conveyors

The following activities are performed on stationary conveyors:

- Installation
- Drum replacement
- Repairs
- Tension adjustments
- Cleaning

DANGER

It is imperative that OSHA/MSHA Lockout/Tagout (LOTO) regulations, 29 CFR 1910.147, be followed before undertaking the preceding activities. Failure to use LOTO exposes workers to uncontrolled behavior of the belt cleaner caused by movement of the conveyor belt. Severe injury or death can result.

Before working:

- Lockout/Tagout the conveyor power source
- Disengage any takeups
- Clear the conveyor belt or clamp securely in place

WARNING

Use Personal Protective Equipment (PPE):

- Safety eyewear
- Hardhats
- Safety footwear

Close quarters, springs and heavy components create a worksite that compromises a worker's eyes, feet and skull.

PPE must be worn to control the foreseeable hazards associated with conveyor belt cleaners. Serious injuries can be avoided.

2.2 Operating Conveyors

There are two routine tasks that must be performed while the conveyor is running:

- Inspection of the cleaning performance
- Dynamic troubleshooting

DANGER

Every belt cleaner is an in-running nip hazard. Never touch or prod an operating cleaner. Cleaner hazards cause instantaneous amputation and entrapment.

WARNING

Belt cleaners can become projectile hazards. Stay as far from the cleaner as practical and use safety eyewear and headgear. Missiles can inflict serious injury.

WARNING

Never adjust anything on an operating cleaner. Unforeseeable belt projections and tears can catch on cleaners and cause violent movements of the cleaner structure. Flailing hardware can cause serious injury or death.

2.3 Other Hazards

WARNING

This cleaner is not intended for use in locations where fire or explosion hazards may exist due to flammable gases or vapors, flammable liquids, combustible dust, or ignitable fibers of flyings.

CAUTION

Wiring of the motor must be done by a qualified electrician. All applicable portions of the following standards must be followed when conducting electric work; NEC Article 430 and Title 30 CFR (specifically part 56 subpart K, part 57 subpart K, and part 77).

Section 3 - Pre-Installation Checks and Options

3.1 Checklist

- Check that the cleaner size is correct for the beltline width
- Check the belt cleaner carton and make sure all the parts are included
- Review the “Tools Needed” list on the top of the installation instructions
- Check the conveyor site:
 - Will the cleaner be installed on a chute
 - Is the install on an open head pulley requiring mounting structure

3.2 Optional Installation Accessories

Optional Mounting Accessories

Description	Ordering Number	Item Code	Wt. Lbs.
Drop Bracket Kit (incl. 2)	MBCDBK	79536	28.9

Lead time: 1 working day

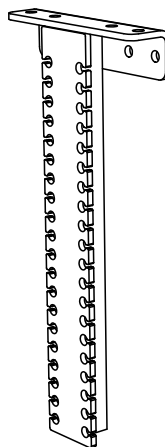

Section 4 - Installation Instructions- Motorized Brush Cleaner

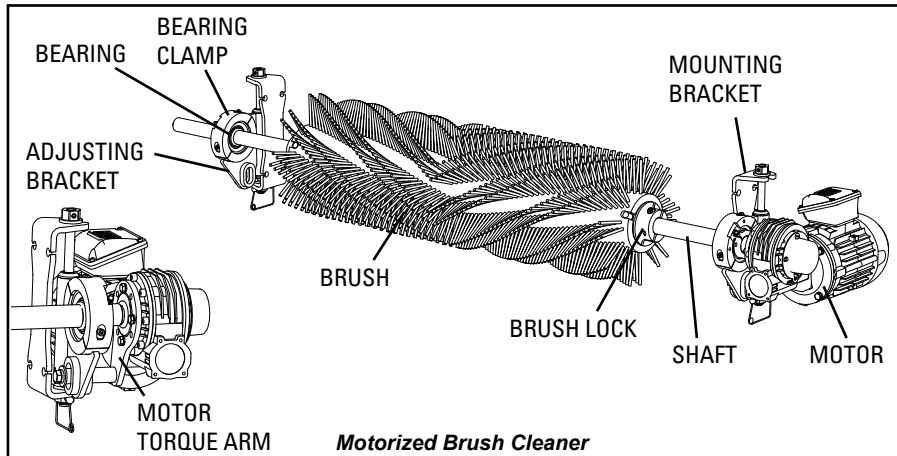

Tools Needed:

- Tape Measure
- 3/4" (19mm) Wrench
- Ratchet with 3/4" (19mm) Socket
- 1-1/8" (29mm) Wrench
- (2) 6" (150mm) Clamps
- Cutting torch and/or welder
- Marking Pen
- Standard/slotted Screwdriver
- 5/16" (9mm) Allen Wrench (provided)
- 3/16" Allen Wrench

PHYSICALLY LOCK OUT AND TAG THE CONVEYOR AT THE POWER SOURCE BEFORE YOU BEGIN CLEANER INSTALLATION.

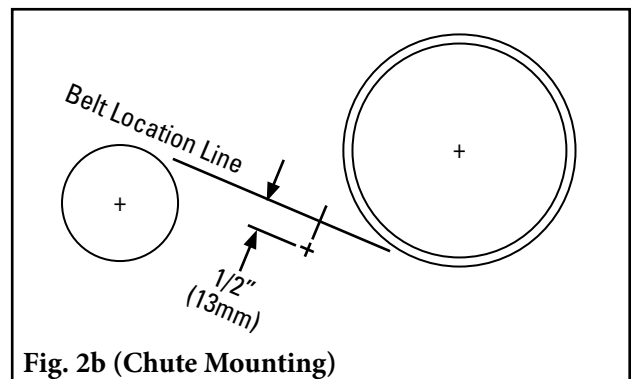
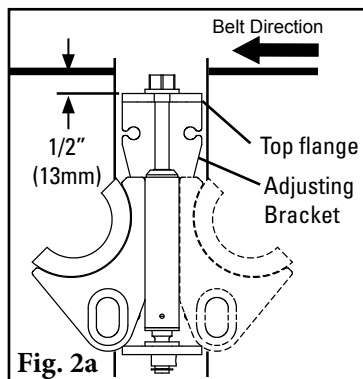
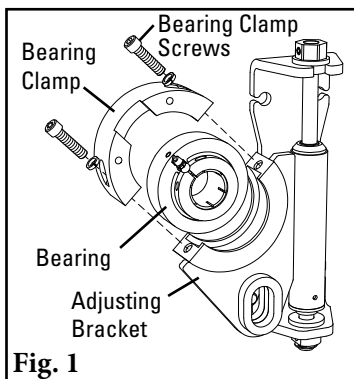
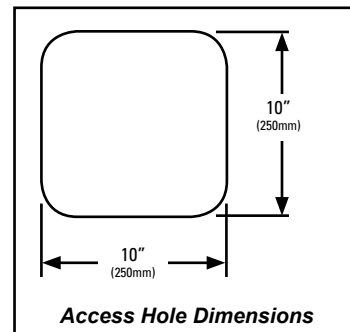
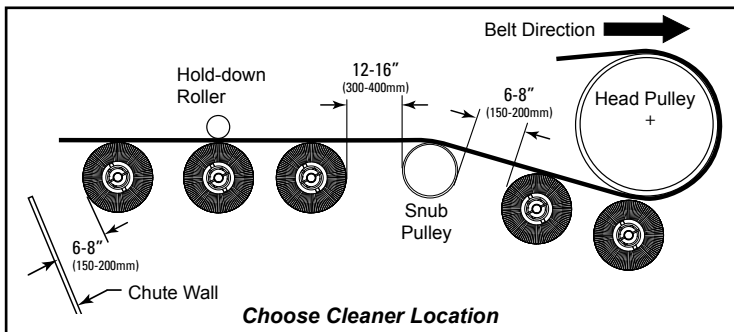

1. Remove Bearings from Adjusting Brackets.

Loosen and remove bearing clamp screws. Take off bearing clamps and remove bearings from adjusting brackets (Fig. 1).

2. Install Adjusting Brackets.

Brackets may be mounted either leading or trailing the direction of belt travel. Clamp mounting bracket into position so the top flange is 1/2" (13mm) below the bottom of the belt (Fig. 2a). Bolt or weld adjusting bracket in place. Locate and install other adjusting bracket on the opposite side.

NOTE: For chute mounting, a belt location line must be drawn on the chute wall so the mounting base can be aligned with the belt (Fig. 2b). Cut access holes as needed.

Section 4 - Installation Instructions (cont.)

3. **Assemble brush to shaft.** Determine which side of the conveyor the motor will go on. The drive end of the shaft must be located on this side (drive end detail shown in Fig. 3c). Choose appropriate motor/brush configuration from the diagrams below (Fig. 3a). Slide brush onto shaft per selected configuration. **NOTE: 'Chevron' bristle pattern should be pointing against the direction of belt travel** (Fig. 3b). Then slide a brush lock on each end of the shaft and into end of the brush, aligning pins on brush lock with notches in the brush (Fig. 3c).

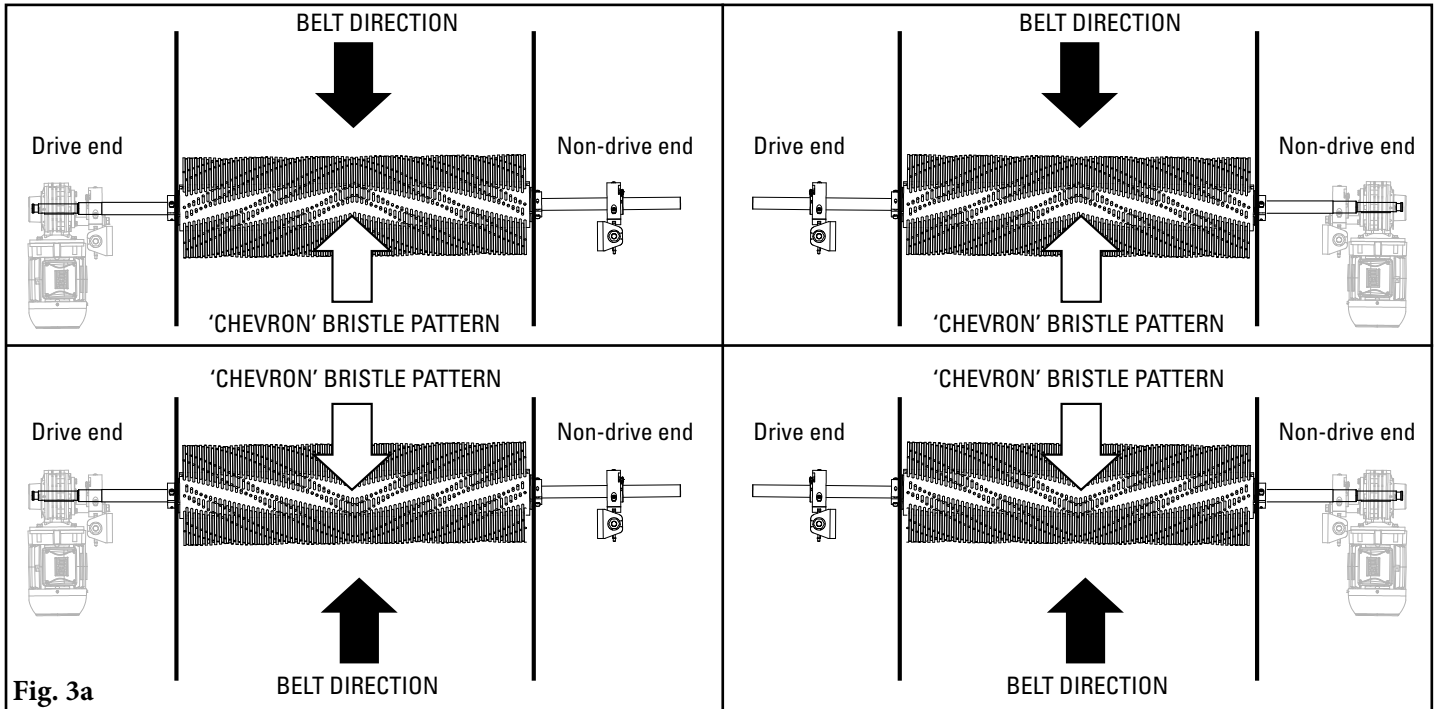

Fig. 3a

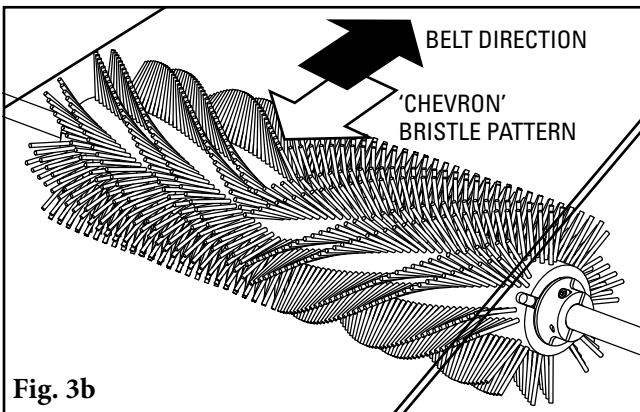

Fig. 3b

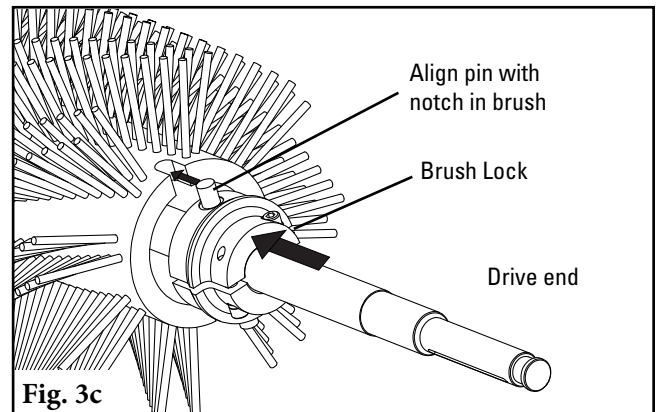

Fig. 3c

4. **Assemble bearings to shaft.** Slide a bearing onto the drive end of the shaft with clamp ring facing the end of the shaft (Fig. 4). The bearing will stop when it hits a small step in the shaft. Tighten the clamp ring with Torx wrench (provided). Slide the other bearing onto the non-drive end of the shaft with clamp ring facing the shaft end; do NOT tighten the clamp ring.

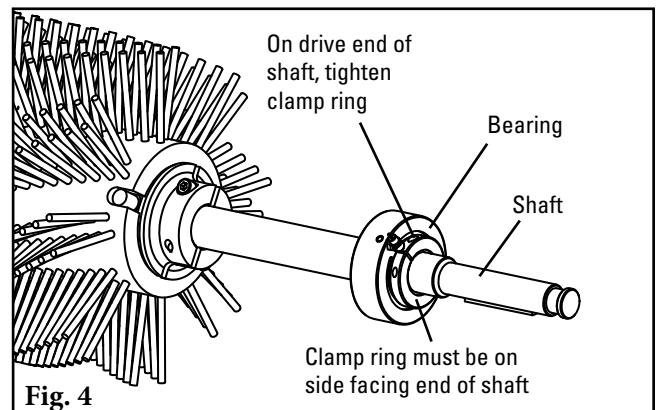
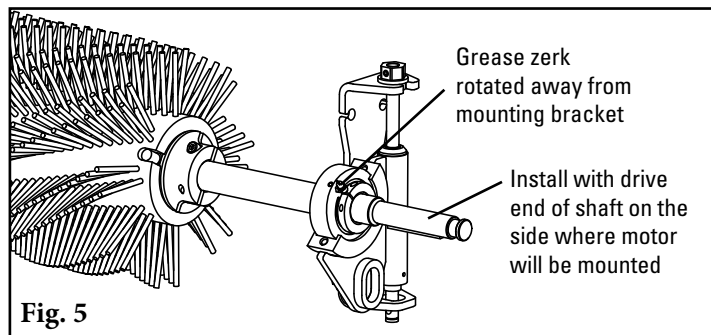

Fig. 4

Section 4 - Installation Instructions (cont.)

5. **Install completed shaft assembly in adjusting brackets.** Place the bearing that is on the drive end of the shaft into the adjusting bracket on the side of the conveyor where the motor will be mounted. Place the bearing on the non-drive end of the shaft into the other adjusting bracket. Ensure bearing grease zerks are rotated away from and not interfering with the adjusting brackets (Fig. 5).



6. **Secure bearings in adjustment brackets.** Replace bearing clamps on both sides, then tighten clamp screws (Fig. 6a). Ensure that the adjusting brackets are square to conveyor structure on both sides, then tighten the non-drive side bearing clamp ring (Fig. 6b). Finally, center brush on the belt and tighten screws on each brush lock (Fig. 6c).

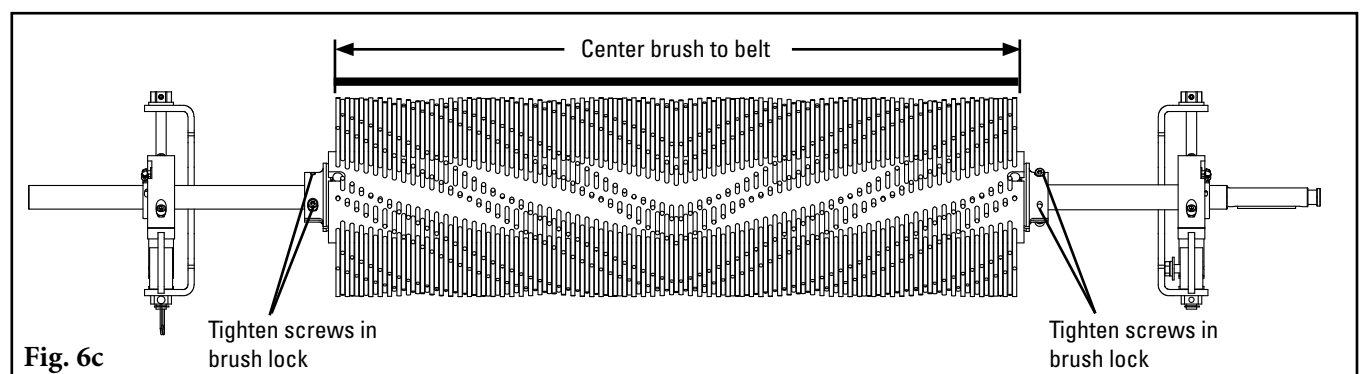
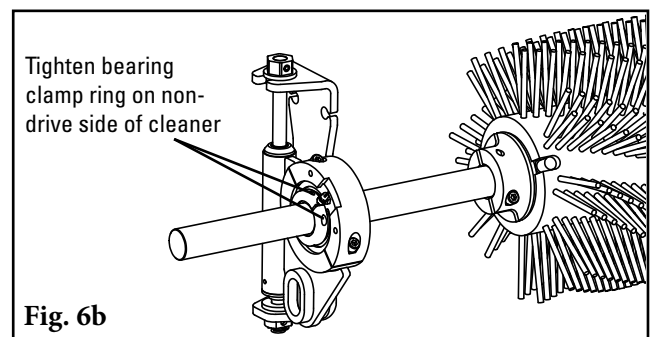
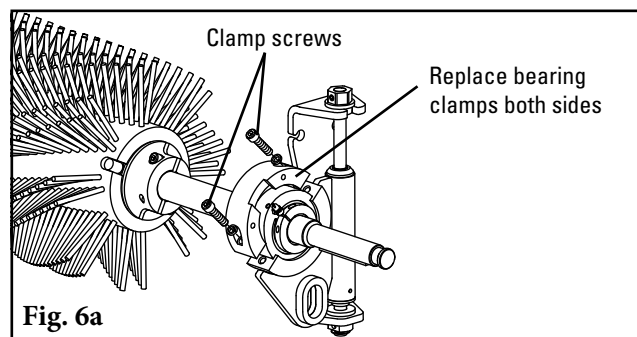

Section 4 - Installation Instructions (cont.)

7. **Determine desired motor mounting orientation.** The motor can be mounted in any of the orientations shown below (Fig. 7).

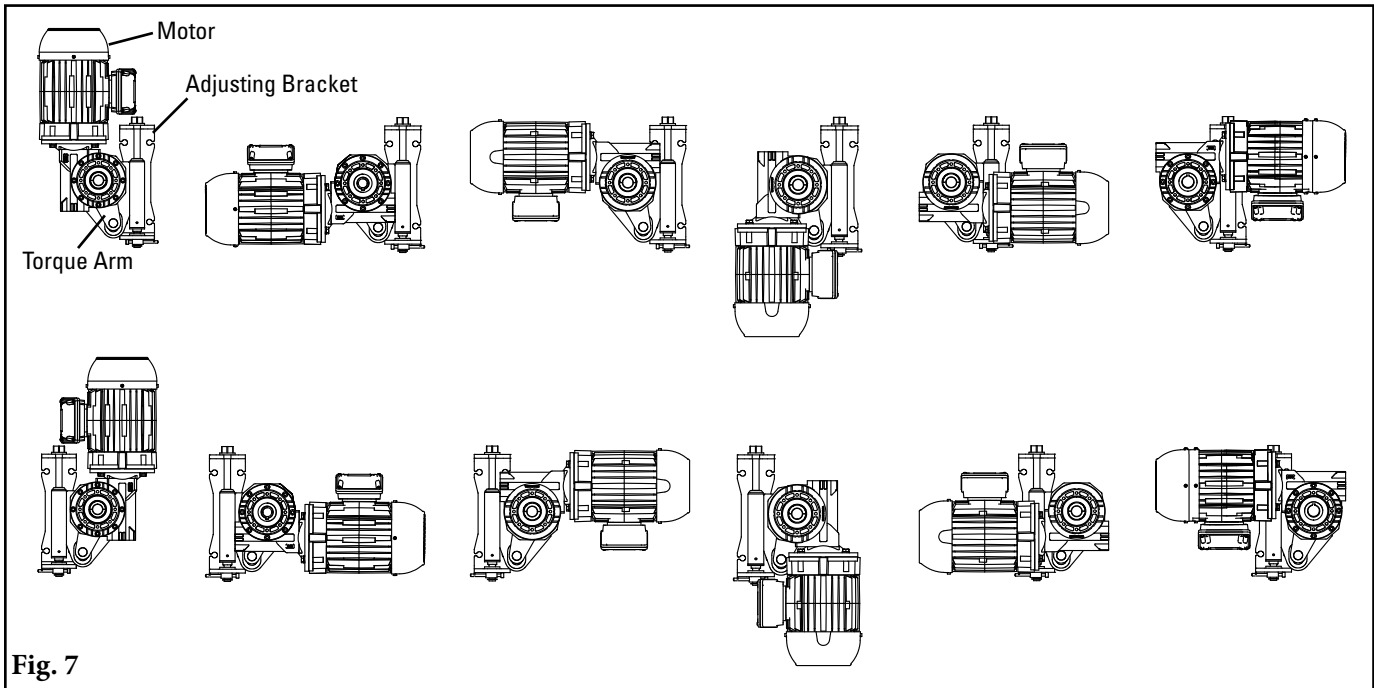

Fig. 7

8. **Install motor.** Orient the torque arm on the motor in order to achieve selected motor orientation and attach with torque arm bolts and washers. Install key into drive end of shaft, then slide motor onto shaft (Fig. 8). Align keyway on motor with key on shaft and slide motor until pin on torque arm is fully through slot on adjustment bracket. Secure motor by installing torque arm pin bolt and washers into end of torque arm pin. Then install shaft collar onto the end of the main shaft.

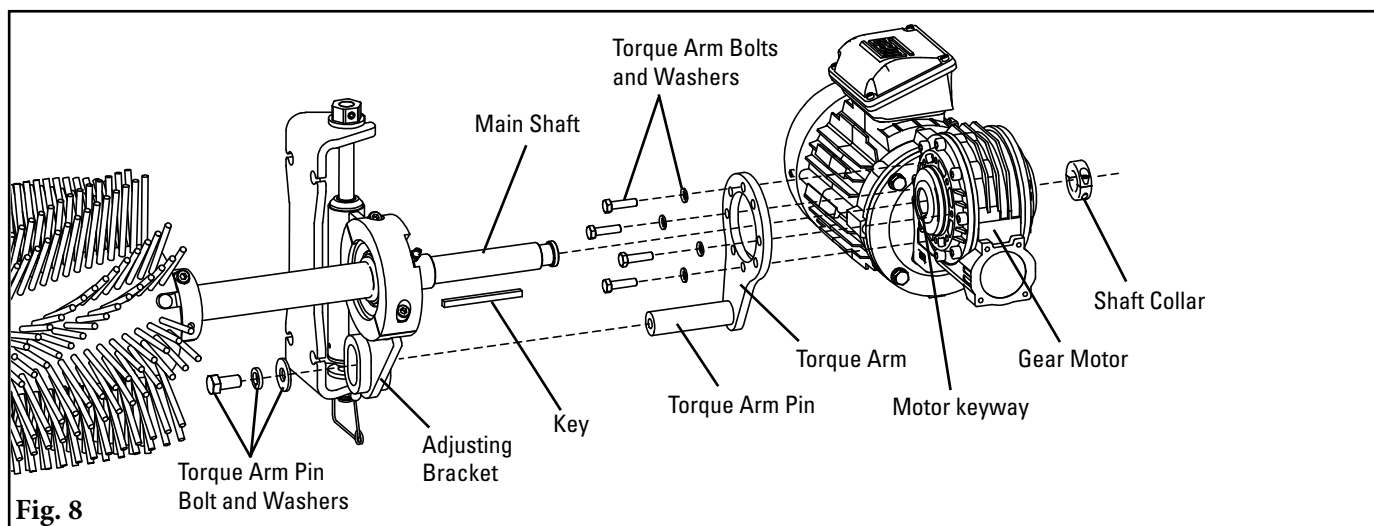

Fig. 8

Section 4 - Installation Instructions (cont.)

9. **Wire the motor.** Wiring should be done by a qualified electrician. It is recommended that the cleaner rotates **only** while the conveyor belt is moving; wire as necessary with conveyor controls to achieve this. Use flexible conduit when terminating into motor junction box; this will allow the cleaner to be adjusted up as the brush wears. Wire motor per connections shown on motor nameplate. Verify motor rotates according to Fig. 3 (brush needs to rotate opposite the direction of the belt); rewire if necessary to switch motor rotation.

ALWAYS VERIFY WIRING ON MOTOR NAMEPLATE

208-230 / 460V MOTOR

LOW VOLTAGE 208-230V (60HZ)

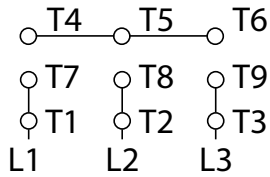

HIGH VOLTAGE

460-480V (60HZ)
380-415V (50HZ)

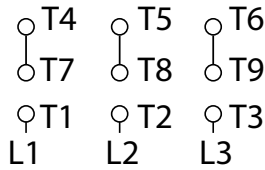

575V MOTOR

RUN

575V (60HZ)
475-520V (50HZ)

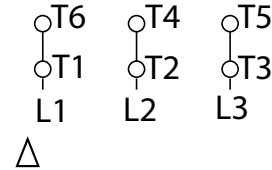

10. **Set brush height.** Remove lock pin from both adjustment brackets (Fig. 10a). Turn adjustment nuts to raise brush until brush bristles just touch belt surface. The brush hub should now be 3-1/4" (83mm) below the bottom of the belt. Once bristles are touching belt, turn adjustment nut an additional 1-1/2 turns. The bristles should be compressed against the belt and brush hub should now be 3" (76mm) below the bottom of the belt (Fig. 10b). Place lock pins back into adjusting brackets.

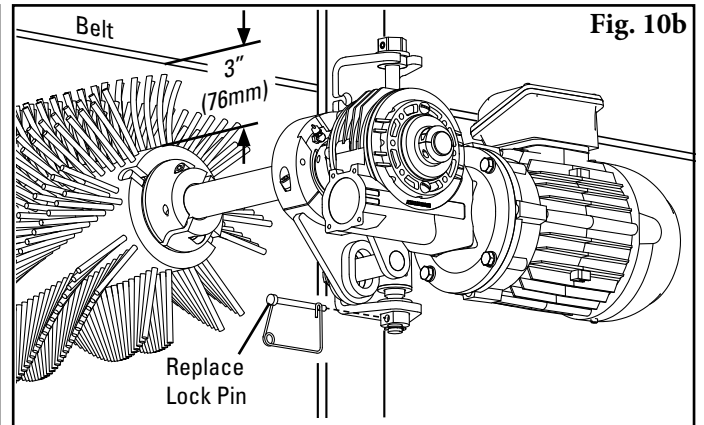
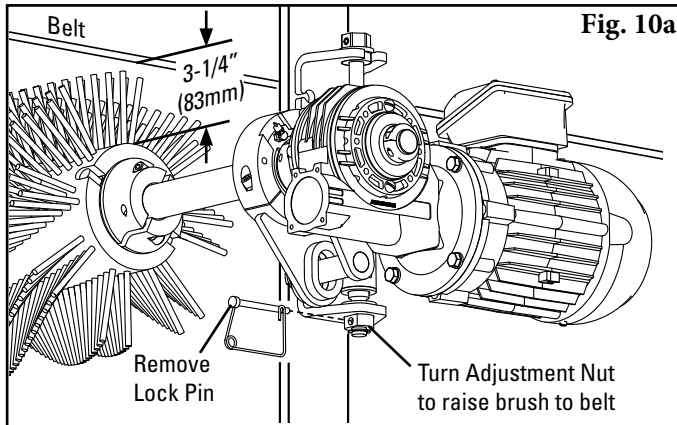

11. **Install shaft covers and 'Danger' labels on endcaps.** Cut off excess shaft if necessary (Fig. 11a and 11b).

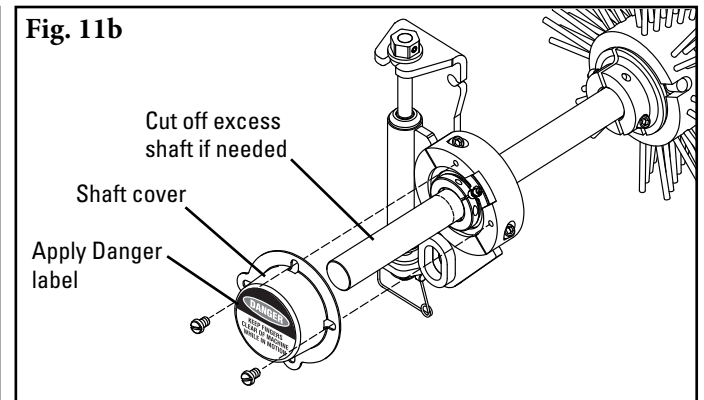
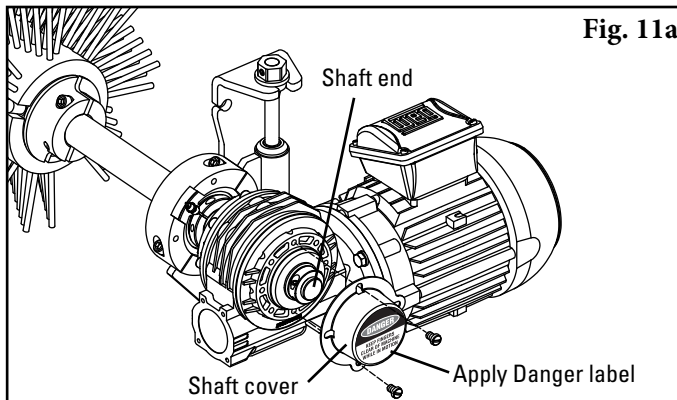

Section 5 - Pre-Operation Checklist and Testing

5.1 Pre-Op Checklist

- Recheck that all fasteners are tightened properly
- Apply all supplied labels to the cleaner
- Check the drum location on the belt
- Be sure that all installation materials and tools have been removed from the belt and the conveyor area

5.2 Test Run the Conveyor

- Run the conveyor for at least 15 minutes and inspect the cleaning performance
- Check the drum and bristles for proper tensioning
- Ensure brush is rotating in correct direction (opposite belt travel direction)
- Make adjustments as necessary

NOTE: Observing the cleaner when it is running and performing properly will help to detect problems or when adjustments are needed later.

Section 6 - Maintenance

Flexco belt cleaners are designed to operate with minimum maintenance. However, to maintain superior performance some service is required. When the cleaner is installed a regular maintenance program should be set up. This program will ensure that the cleaner operates at optimal efficiency and problems can be identified and fixed before the cleaner stops working.

All safety procedures for inspection of equipment (stationary or operating) must be observed. The Motorized Brush Cleaner operates at the discharge end of the conveyor and is in direct contact with the moving belt. Only visual observations can be made while the belt is running. Service tasks can be done only with the conveyor stopped and by observing the correct lockout/tagout procedures.

6.1 New Installation Inspection

After the new cleaner has run for a few days a visual inspection should be made to ensure the cleaner is performing properly. Make adjustments as needed.

6.2 Routine Visual Inspection (every 2-4 weeks)

A visual inspection of the cleaner and belt should look for:

- If belt looks clean or if there are areas that are dirty
- If cleaner is worn out and needs to be replaced
- If there is damage to the cleaner or other cleaner components
- If fugitive material is built up on cleaner or in the transfer area
- If there is cover damage to the belt
- If a snub pulley is used, a check should be made for material buildup on the pulley
- Significant signs of carryback
- If any of the above conditions exist, a determination should be made on when the conveyor can be stopped for cleaner maintenance.

6.3 Routine Physical Inspection (every 6-8 weeks)

When the conveyor is not in operation and properly locked and tagged out, a physical inspection of the cleaner to perform the following tasks:

- Clean material buildup off of the cleaner
- Closely inspect the cleaner for wear and any damage. Replace if needed.
- Ensure full cleaner to belt contact
- Inspect the cleaner for damage
- Inspect all fasteners for tightness and wear. Tighten or replace as needed.
- Grease bearings
- Replace any worn or damaged components
- When maintenance tasks are completed, test run the conveyor to ensure the cleaner is performing properly.

Section 6 - Maintenance

6.4 Brush Replacement Instructions

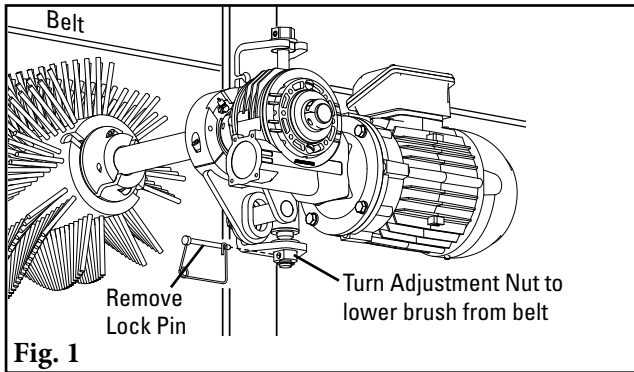

Tools Needed:

- Tape Measure
- 1-1/8" (29mm) wrench
- 5/16" (8mm) Allen wrench

1. **Lower brush all the way down from the belt.** Remove lock pins and turn the adjusting nuts to lower the brush to bottom of adjustment range (Fig.1).

2a. **Remove bearing clamp on non-drive side.** Remove clamp screws and bearing clamp (Fig. 2a.)

2b. **If non-drive side is inaccessible,** remove motor from drive end of shaft (Fig. 2b), then remove clamp screws and bearing clamp (Fig. 2a).

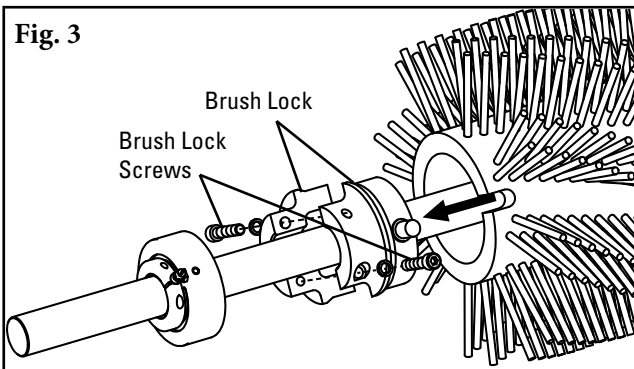
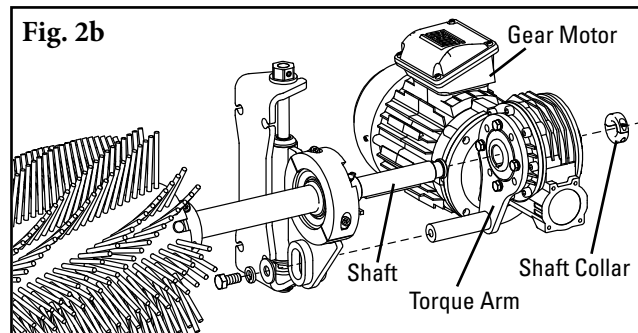
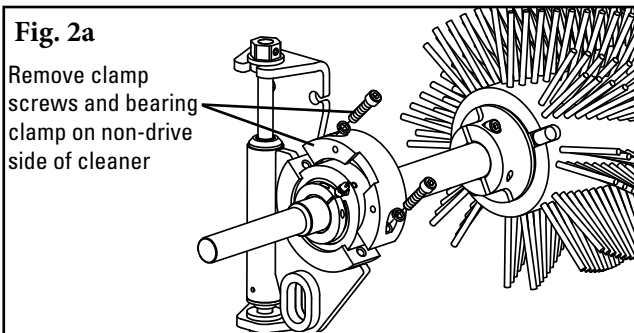

3. **Remove worn brush.** Remove brush lock screws and brush lock. Then slide the brush over the bearing and off the shaft (Fig 3.)

4. **Assemble new brush to the shaft.**

Orient the new brush with the chevron pattern pointing opposite the direction of belt travel (Fig. 4a). Slide the brush over the bearing and reinstall the brush lock, aligning pin with notch in brush (Fig. 4b).

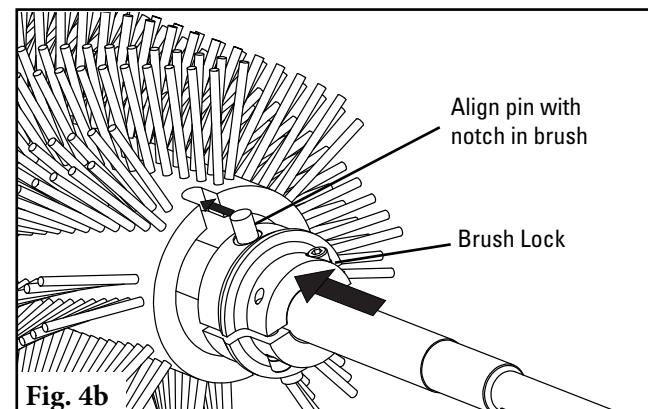
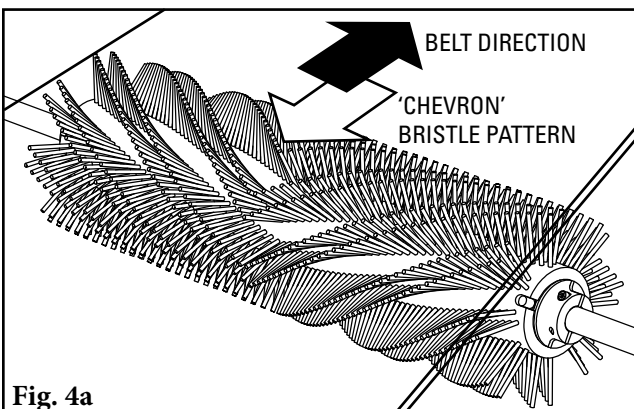

Section 6 - Maintenance

6.4 Brush Replacement Instructions Cont.

5. Replace bearing in adjustment bracket and reinstall bearing clamp. Tighten clamp screws (Fig. 5).

5a. If motor was removed, reinstall.

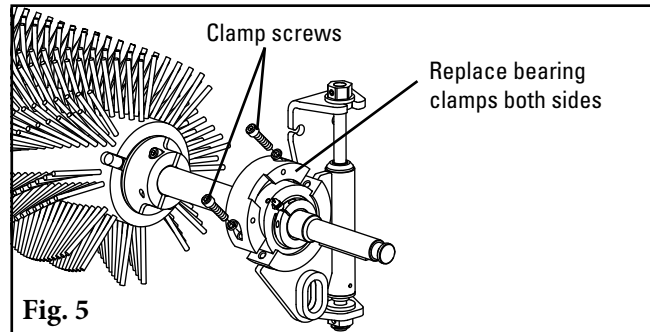

6. Center brush on the belt and tighten screws on brush locks (Fig. 6).

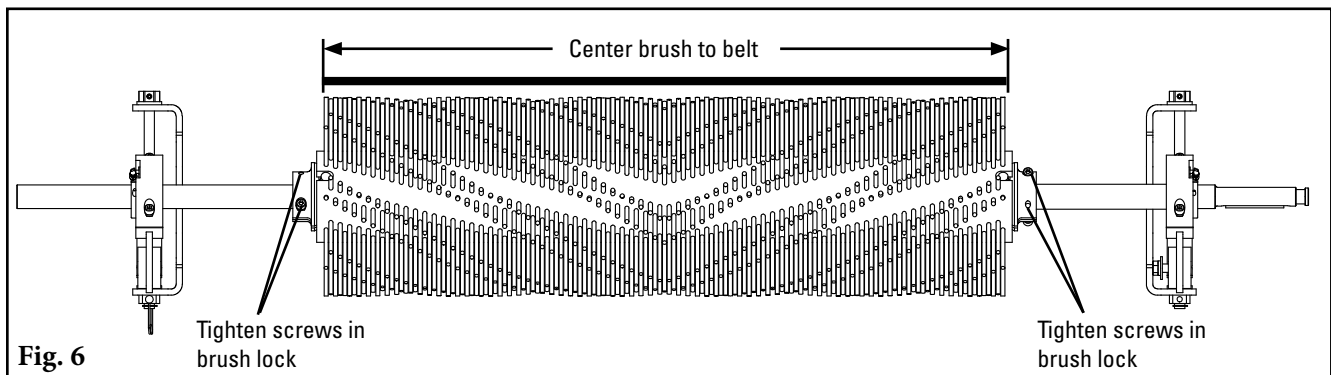

7. **Set brush height.** Turn adjustment nuts to raise brush until brush bristles just touch belt surface. The brush hub should now be $3\text{-}1/4$ " (83mm) below the bottom of the belt. Once bristles are touching belt, turn adjustment nut an additional $1\text{-}1/2$ turns. The bristles should be compressed against the belt and brush hub should now be 3" (76mm) below the bottom of the belt (Fig. 7b). Place adjustment lock pins back into adjusting brackets.

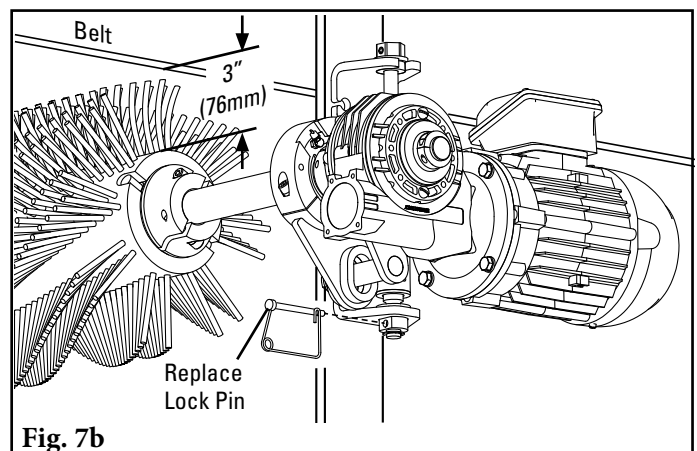
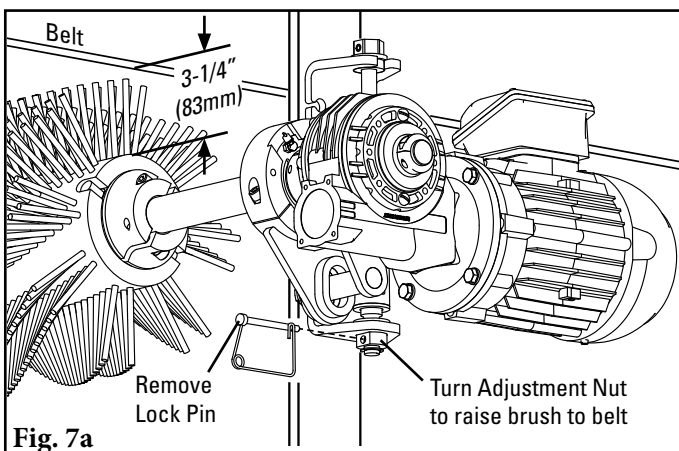

Section 6 - Maintenance

6.5 Maintenance Log

Conveyor Name/No. _____

Date: _____ Work done by: _____ Service Quote # _____

Activity: _____

Date: _____ Work done by: _____ Service Quote # _____

Activity: _____

Date: _____ Work done by: _____ Service Quote # _____

Activity: _____

Date: _____ Work done by: _____ Service Quote # _____

Activity: _____

Date: _____ Work done by: _____ Service Quote # _____

Activity: _____

Date: _____ Work done by: _____ Service Quote # _____

Activity: _____

Date: _____ Work done by: _____ Service Quote # _____

Activity: _____

Section 6 - Maintenance

6.6 Cleaner Maintenance Checklist

Belt Cleaner: _____ Serial Number: _____

Beltline Information:

Beltline Number: _____ Belt Condition: _____

Belt Width: 18" 24" 30" 36" 42" 48" 54" 60" 72" 84"
(450mm) (600mm) (750mm) (900mm) (1050mm) (1200mm) (1350mm) (1500mm) (1800mm) (2100mm)

Head Pulley Diameter (Belt & Lagging): _____ Belt Speed: _____ fpm Belt Thickness: _____

Belt Splice _____ Condition of Splice _____ Number of splices _____ Skived Unskived

Material conveyed _____

Days per week run _____ Hours per day run _____

Drum Life:

Date installed: _____ Date inspected: _____ Estimated life: _____

Is cleaner making complete contact with belt? Yes No

Drum condition: Good Not contacting belt Damaged

Was Cleaner Adjusted: Yes No

Shaft Condition: Good Bent Worn

Lagging: Slide lag Ceramic Rubber Other None

Condition of lagging: Good Bad Other _____

Cleaner's Overall Performance: (Rate the following 1 - 5, 1=very poor - 5= very good)

Appearance: Comments: _____

Location: Comments: _____

Maintenance: Comments: _____

Performance: Comments: _____

Other Comments: _____



Section 7 - Troubleshooting

Problem	Possible Cause	Possible Solutions
Vibration	Cleaner secure bolts not set	Ensure all locking nuts are tight (Loctite)
	Cleaner not set up correctly	Ensure cleaner set up properly
	Belt tension too high	Ensure cleaner can conform to belt, or replace with alternate Flexco secondary cleaner
	Belt flap	Introduce hold-down roller to flatten belt
	Cleaner over-tensioned	Ensure cleaner is correctly tensioned
	Cleaner under-tensioned	Ensure cleaner is correctly tensioned
Material buildup on cleaner	Cleaner not set up correctly	Ensure cleaner set up properly
	Buildup on chute	Ensure cleaner is not located too close to back of chute, allowing buildup
	Cleaner being overburdened	Introduce Flexco precleaner (if not a chevron belt)
	Excessive sticky material	Frequently clean unit of buildup
Damaged belt cover	Cleaner over-tensioned	Ensure cleaner is correctly tensioned
	Cleaner bristles damaged	Check bristles for wear, damage and chips, replace where necessary
	Material buildup in chute	Frequently clean unit of buildup
	Brush is running when conveyor is not	Check brush motor wiring
Cleaner not conforming to belt	Cleaner not set up correctly	Ensure cleaner set up properly
	Belt tension too high	Ensure cleaner can conform to belt, or replace with alternate Flexco secondary cleaner
	Belt flap	Introduce hold-down roller to flatten belt
	Cleaner cannot conform	Ensure cleaner can conform to belt, or replace with alternate Flexco secondary cleaner
Material passing cleaner	Cleaner not set up correctly	Ensure cleaner set up properly
	Cleaner tension too low	Ensure cleaner is correctly tensioned
	Cleaner bristles worn/damaged	Check bristles for wear, damage and chips, replace where necessary
	Cleaner being overburdened	Introduce Flexco precleaner
	Belt flap	Introduce hold-down roller to flatten belt
	Cleaner cannot conform	Ensure cleaner can conform to belt, or replace with alternate Flexco secondary cleaner
Missing material in belt center only	Cleaner shaft located too high	Ensure cleaner set up properly
	Cleaner bristles worn/damaged	Check bristles for wear, damage and chips, replace where necessary
Missing material on outer edges only	Cleaner shaft located too low	Ensure cleaner set up properly
	Cleaner bristles worn/damaged	Check bristles for wear, damage and chips, replace where necessary

Section 8 - Specs and CAD Drawings

8.1 Specs and Guidelines

Specifications

Belt Speed	Up to 700 fpm (3.5M/sec)
Vertical and Horizontal Clearance	12" (305mm)
Temperature Range	-20°F to 180°F (-30°C to 82°C)
Maximum Chevron or Cleat Height	1/2" (13mm)
Bristle Length	3-1/4" (83mm)
Overall Diameter	12" (305mm)
Shaft Length	Belt Width plus 42" (1067mm)
Shaft Diameter	1-1/2" (38mm)
Motor Voltage and HP Options	208-230/460VAC 3 Phase* 1 HP (cleaners 18-42" (450-1050mm)) 2 HP (cleaners 48-84" (1200-2100mm))
	575V 3 Phase* 1 HP (cleaners 18-36" (450-900mm)) 2 HP (cleaners 42-84" (1050-2100mm))
CEMA Cleaner Rating	Class 4

*Other motors available upon request

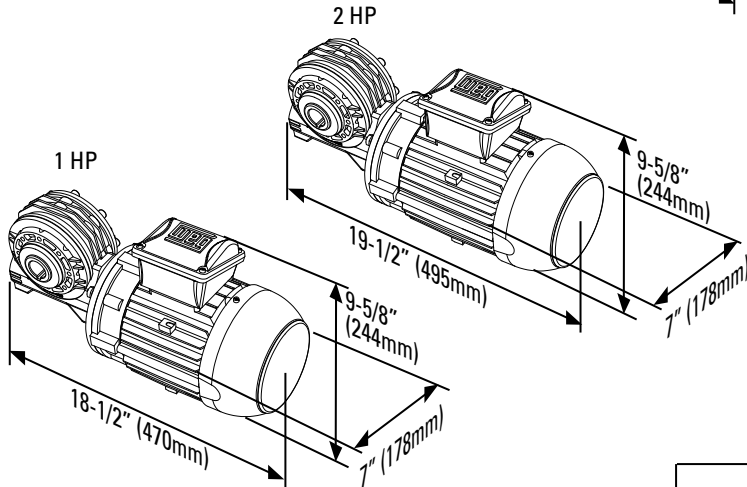
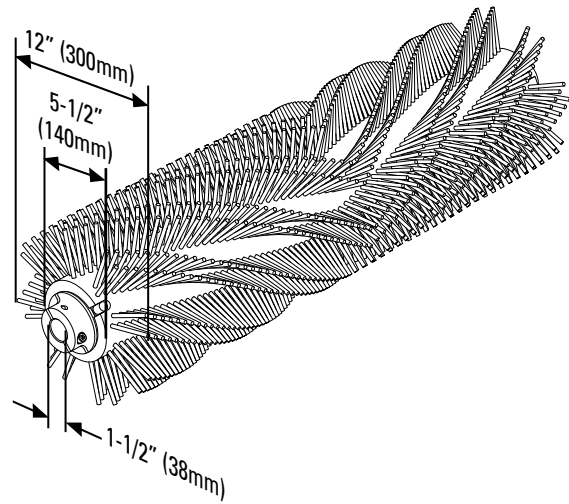
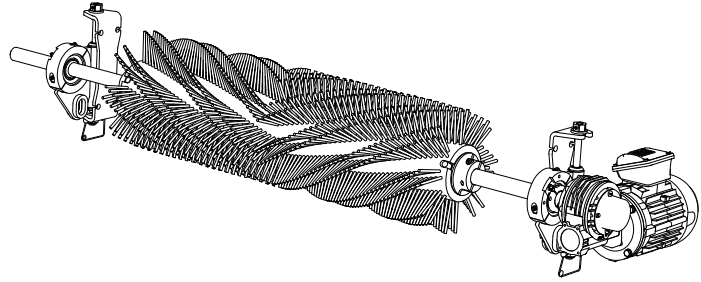

Shaft Measurements

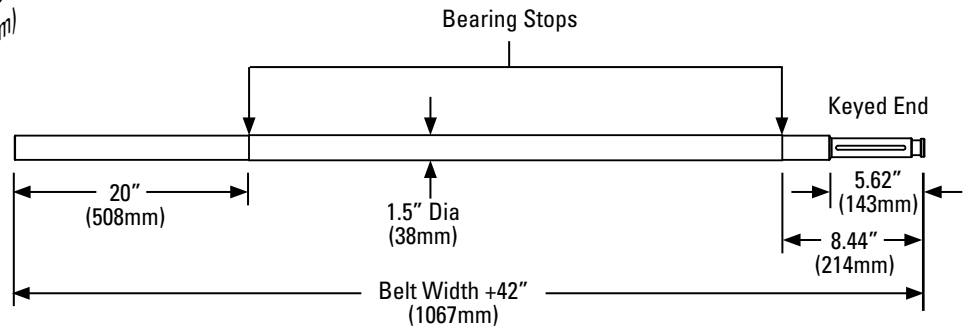

Product Notes:

- Spins opposite the belt direction for optimal cleaning.
- Uniquely patterned bristles aid in reducing material buildup and clogging.
- Adjustable tensioners allow easy brush-to-belt adjustment as the bristles wear.
- Works on mechanically spliced or vulcanized belts.

Section 8 - Specs and CAD Drawings

8.2 CAD Drawing

SPECIFICATIONS						MBC CLEANER 208-230/460VAC MOTOR		ITEM 1 BRUSH		ITEM 2 SHAFT		ITEM 3 208-230/460VAC 3 Phase GEARMOTOR		
BELT WIDTH "A"		SHAFT LENGTH "B"		MOTOR LENGTH "C"		ORDER NUMBER	ITEM CODE	ORDER NUMBER	ITEM CODE	ORDER NUMBER	ITEM CODE	ORDER NUMBER	ITEM CODE	HORSE- POWER
in	mm	in	mm	in	mm									
18	450	60	1524	19	483	MBC-18	79494	MBRD-18	79514	MBDS-18	79504	MBCM-1	79529	1
24	600	66	1676	19	483	MBC-24	79495	MBRD-24	79515	MBDS-24	79505	MBCM-1	79529	1
30	750	72	1829	19	483	MBC-30	79496	MBRD-30	79516	MBDS-30	79506	MBCM-1	79529	1
36	900	78	1981	19	483	MBC-36	79497	MBRD-36	79517	MBDS-36	79507	MBCM-1	79529	1
42	1050	84	2134	19	483	MBC-42	79498	MBRD-42	79518	MBDS-42	79508	MBCM-1	79529	1
48	1200	90	2286	20	508	MBC-48	79499	MBRD-48	79519	MBDS-48	79509	MBCM-2	79530	2
54	1350	96	2438	20	508	MBC-54	79500	MBRD-54	79520	MBDS-54	79510	MBCM-2	79530	2
60	1500	102	2591	20	508	MBC-60	79501	MBRD-60	79521	MBDS-60	79511	MBCM-2	79530	2
72	1800	114	2896	20	508	MBC-72	79502	MBRD-72	79522	MBDS-72	79512	MBCM-2	79530	2
84	2100	126	3200	20	508	MBC-84	79503	MBRD-84	79523	MBDS-84	79513	MBCM-2	79530	2

SPECIFICATIONS						MBC CLEANER 575V MOTOR		ITEM 1 BRUSH		ITEM 2 SHAFT		ITEM 3 575V 3 Phase GEARMOTOR		
BELT WIDTH "A"		SHAFT LENGTH "B"		MOTOR LENGTH "C"		ORDER NUMBER	ITEM CODE	ORDER NUMBER	ITEM CODE	ORDER NUMBER	ITEM CODE	ORDER NUMBER	ITEM CODE	HORSE- POWER
in	mm	in	mm	in	mm									
18	450	60	1524	19	483	MBC-18-575V	79914	MBRD-18	79514	MBDS-18	79504	MBCM-575-1	79924	1
24	600	66	1676	19	483	MBC-24-575V	79915	MBRD-24	79515	MBDS-24	79505	MBCM-575-1	79924	1
30	750	72	1829	19	483	MBC-30-575V	79916	MBRD-30	79516	MBDS-30	79506	MBCM-575-1	79924	1
36	900	78	1981	19	483	MBC-36-575V	79917	MBRD-36	79517	MBDS-36	79507	MBCM-575-1	79924	1
42	1050	84	2134	20	508	MBC-42-575V	79918	MBRD-42	79518	MBDS-42	79508	MBCM-575-2	79925	1
48	1200	90	2286	20	508	MBC-48-575V	79919	MBRD-48	79519	MBDS-48	79509	MBCM-575-2	79925	2
54	1350	96	2438	20	508	MBC-54-575V	79920	MBRD-54	79520	MBDS-54	79510	MBCM-575-2	79925	2
60	1500	102	2591	20	508	MBC-60-575V	79921	MBRD-60	79521	MBDS-60	79511	MBCM-575-2	79925	2
72	1800	114	2896	20	508	MBC-72-575V	79922	MBRD-72	79522	MBDS-72	79512	MBCM-575-2	79925	2
84	2100	126	3200	20	508	MBC-84-575V	79923	MBRD-84	79523	MBDS-84	79513	MBCM-575-2	79925	2

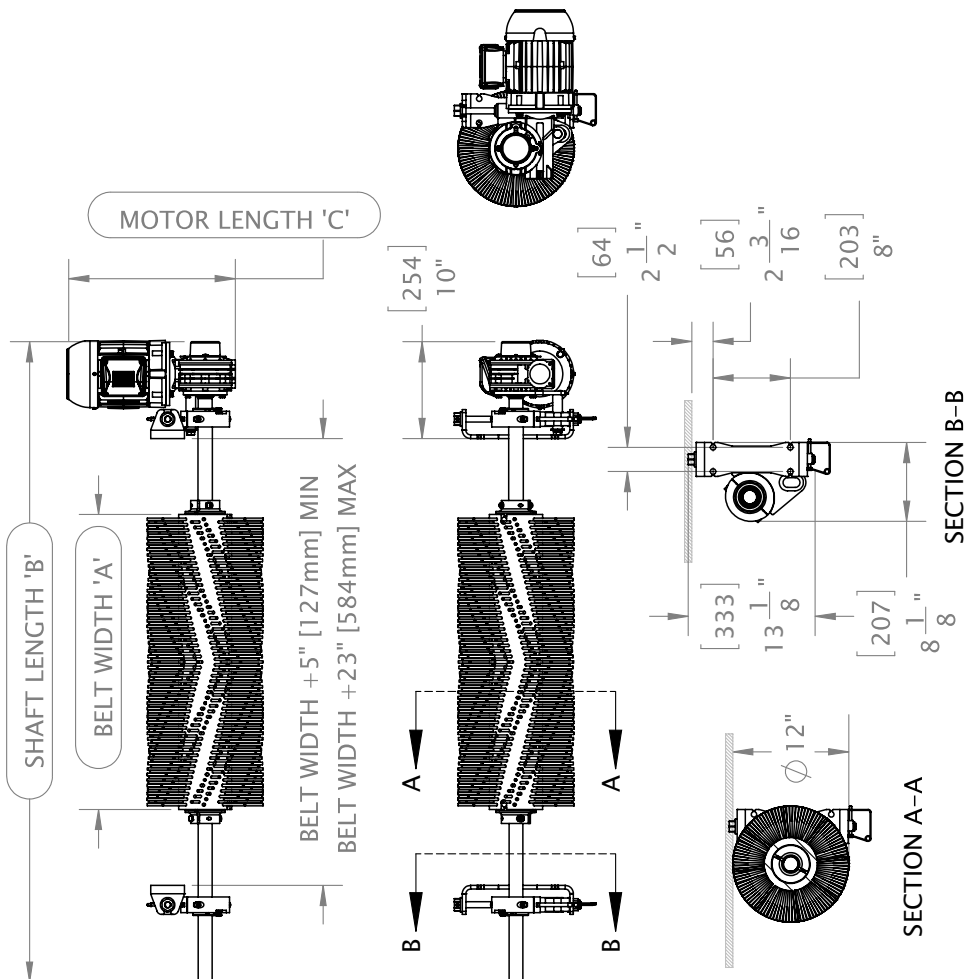

NOTE: MOTOR CAN BE MOUNTED IN OTHER ORIENTATIONS

Section 9 - Replacement Parts

9.1 Replacement Parts List

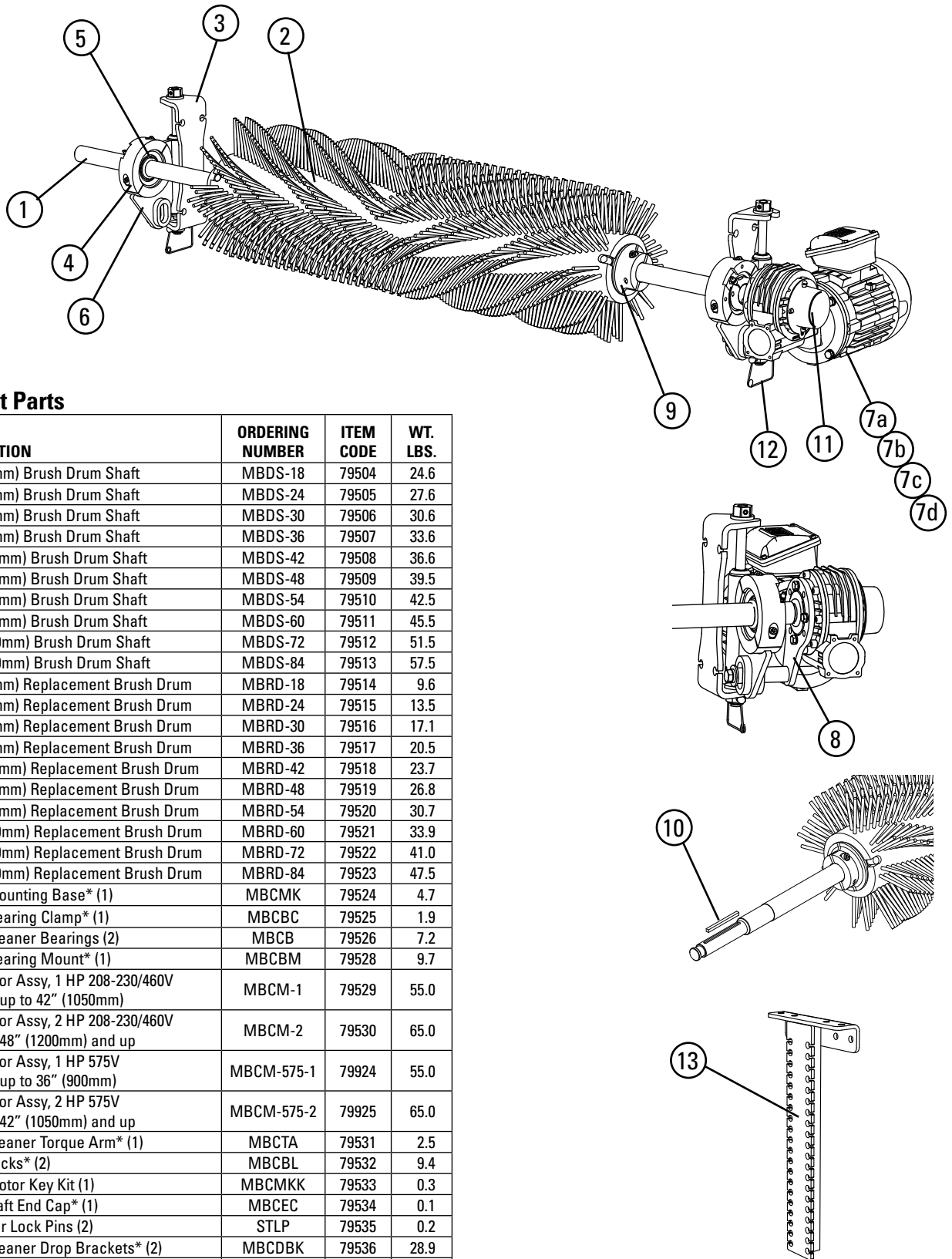

Replacement Parts

REF	DESCRIPTION	ORDERING NUMBER	ITEM CODE	WT. LBS.
1	18" (450mm) Brush Drum Shaft	MBDS-18	79504	24.6
	24" (600mm) Brush Drum Shaft	MBDS-24	79505	27.6
	30" (750mm) Brush Drum Shaft	MBDS-30	79506	30.6
	36" (900mm) Brush Drum Shaft	MBDS-36	79507	33.6
	42" (1050mm) Brush Drum Shaft	MBDS-42	79508	36.6
	48" (1200mm) Brush Drum Shaft	MBDS-48	79509	39.5
	54" (1350mm) Brush Drum Shaft	MBDS-54	79510	42.5
	60" (1500mm) Brush Drum Shaft	MBDS-60	79511	45.5
	72" (1800mm) Brush Drum Shaft	MBDS-72	79512	51.5
84" (2100mm) Brush Drum Shaft	MBDS-84	79513	57.5	
2	18" (450mm) Replacement Brush Drum	MBRD-18	79514	9.6
	24" (600mm) Replacement Brush Drum	MBRD-24	79515	13.5
	30" (750mm) Replacement Brush Drum	MBRD-30	79516	17.1
	36" (900mm) Replacement Brush Drum	MBRD-36	79517	20.5
	42" (1050mm) Replacement Brush Drum	MBRD-42	79518	23.7
	48" (1200mm) Replacement Brush Drum	MBRD-48	79519	26.8
	54" (1350mm) Replacement Brush Drum	MBRD-54	79520	30.7
	60" (1500mm) Replacement Brush Drum	MBRD-60	79521	33.9
	72" (1800mm) Replacement Brush Drum	MBRD-72	79522	41.0
84" (2100mm) Replacement Brush Drum	MBRD-84	79523	47.5	
3	Brush Mounting Base* (1)	MBCMK	79524	4.7
4	Brush Bearing Clamp* (1)	MBCBC	79525	1.9
5	Brush Cleaner Bearings (2)	MBCB	79526	7.2
6	Brush Bearing Mount* (1)	MBCBM	79528	9.7
7a	Gearmotor Assy, 1 HP 208-230/460V for belts up to 42" (1050mm)	MBCM-1	79529	55.0
7b	Gearmotor Assy, 2 HP 208-230/460V for belts 48" (1200mm) and up	MBCM-2	79530	65.0
7c	Gearmotor Assy, 1 HP 575V for belts up to 36" (900mm)	MBCM-575-1	79924	55.0
7d	Gearmotor Assy, 2 HP 575V for belts 42" (1050mm) and up	MBCM-575-2	79925	65.0
8	Brush Cleaner Torque Arm* (1)	MBCTA	79531	2.5
9	Brush Locks* (2)	MBCBL	79532	9.4
10	Brush Motor Key Kit (1)	MBCMCK	79533	0.3
11	MBC Shaft End Cap* (1)	MBCEC	79534	0.1
12	Tensioner Lock Pins (2)	STLP	79535	0.2
13	Brush Cleaner Drop Brackets* (2)	MBCDBK	79536	28.9
-	Brush Cleaner Adjusting Bracket (1) (incl. bearing and 1 ea. items 3,4,6,&12)	MBADB	79527	18.1

*Hardware Included

Lead time: 1 working day

Section 10 - Other Flexco Conveyor Products

Flexco provides many conveyor products that help your conveyors to run more efficiently and safely. These components solve typical conveyor problems and improve productivity. Here is a quick overview on just a few of them:

MMP Precleaner



- Extra cleaning power right on the head pulley
- A 10" (250mm) TuffShear™ blade provides increased blade tension on the belt to peel off abrasive materials
- The unique Visual Tension Check™ ensures optimal blade tensioning and quick, accurate retensioning
- Easy to install and simple to service

DRX Impact Beds



- Exclusive Velocity Reduction Technology™ to better protect the belt
- Slide-Out Service™ gives direct access to all impact bars for change-out
- Impact bar supports for longer bar life
- 4 models to custom fit to the application

MHS Secondary Cleaner with Service Advantage Cartridge

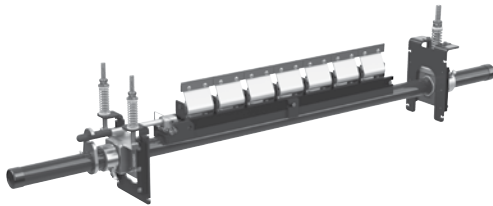

- An easy slide-out cartridge for service
- Cartridge design to speed up blade-change maintenance
- Patented PowerFlex™ Cushions for superior cleaning performance
- Compatible with Flexco mechanical splices

PT Max™ Belt Trainer

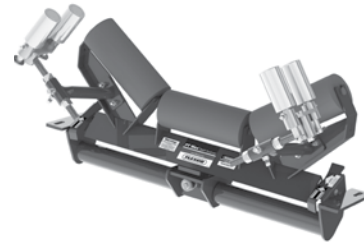

- Patented “pivot & tilt” design for superior training action
- Dual sensor rollers on each side to minimize belt damage
- Pivot point guaranteed not to seize or freeze up
- Available for topside and return side belts

Flexco Specialty Belt Cleaners

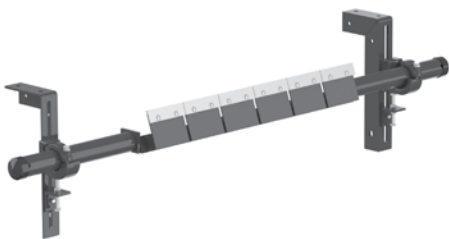

- “Limited space” cleaners for tight conveyor applications
- High Temp cleaners for severe, high heat applications
- Multiple cleaner styles in stainless steel for corrosive applications

Belt Plows



- A belt cleaner for the tail pulley
- Exclusive blade design quickly spirals debris off the belt
- Economical and easy to service
- Available in vee or diagonal models

The Flexco Vision

To become the leader in maximising
belt conveyor productivity for our customers worldwide
through superior service and innovation.

Distribution in Europe by:

Flexco Europe GmbH • Leidringer Strasse 40-42 • D-72348 Rosenfeld • Germany

Phone: +49-7428-9406-0 • Fax: +49-7428-9406-260 • E-mail: europa@flexco.com • Web: www.flexco.com



2525 Wisconsin Avenue • Downers Grove, IL 60515-4200 • USA

Tel: (630) 971-0150 • Fax: (630) 971-1180 • E-mail: info@flexco.com

Visit www.flexco.com for other Flexco locations and products.

©2016 Flexible Steel Lacing Company. 03/16. For reorder: X3575

